

## 18 СХЕМЫ ЭЛЕКТРИЧЕСКИЕ БЛОКОВ

### 18.1 Наружные блоки моделей GMV-Rm224W/Na-M, GMV-Rm280W/Na-M

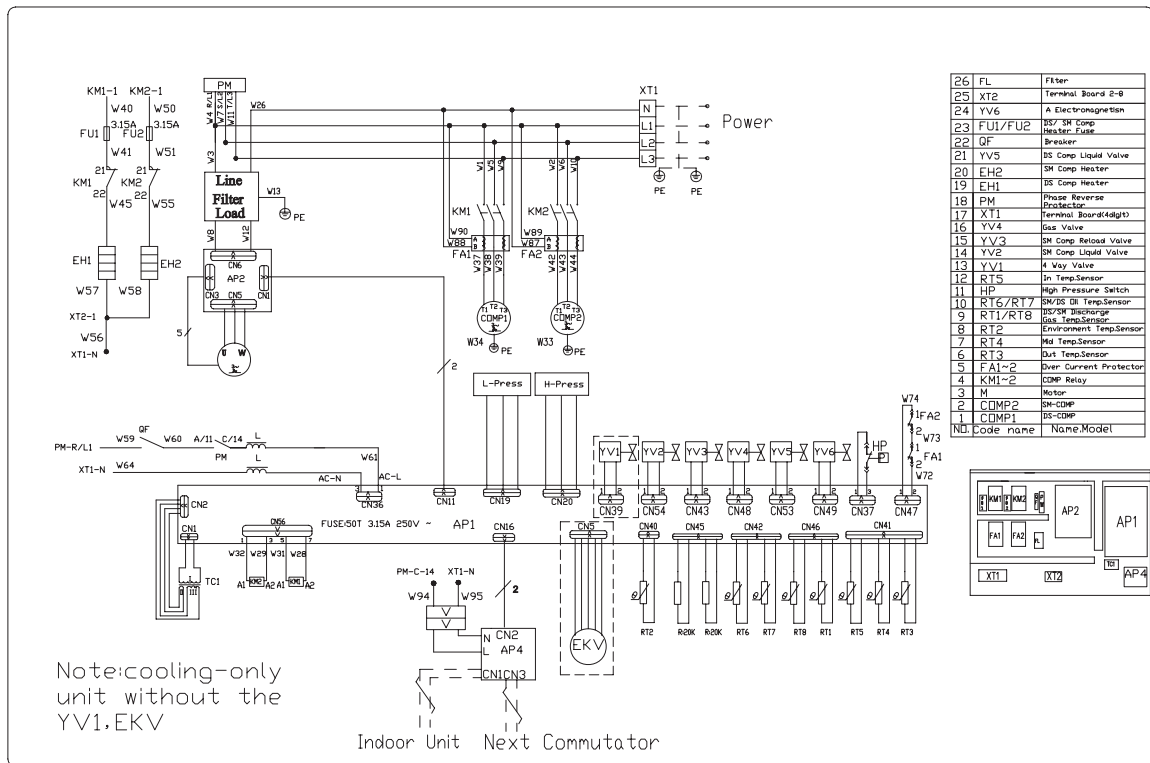

### Модели GMV-Rm335W/Na-M

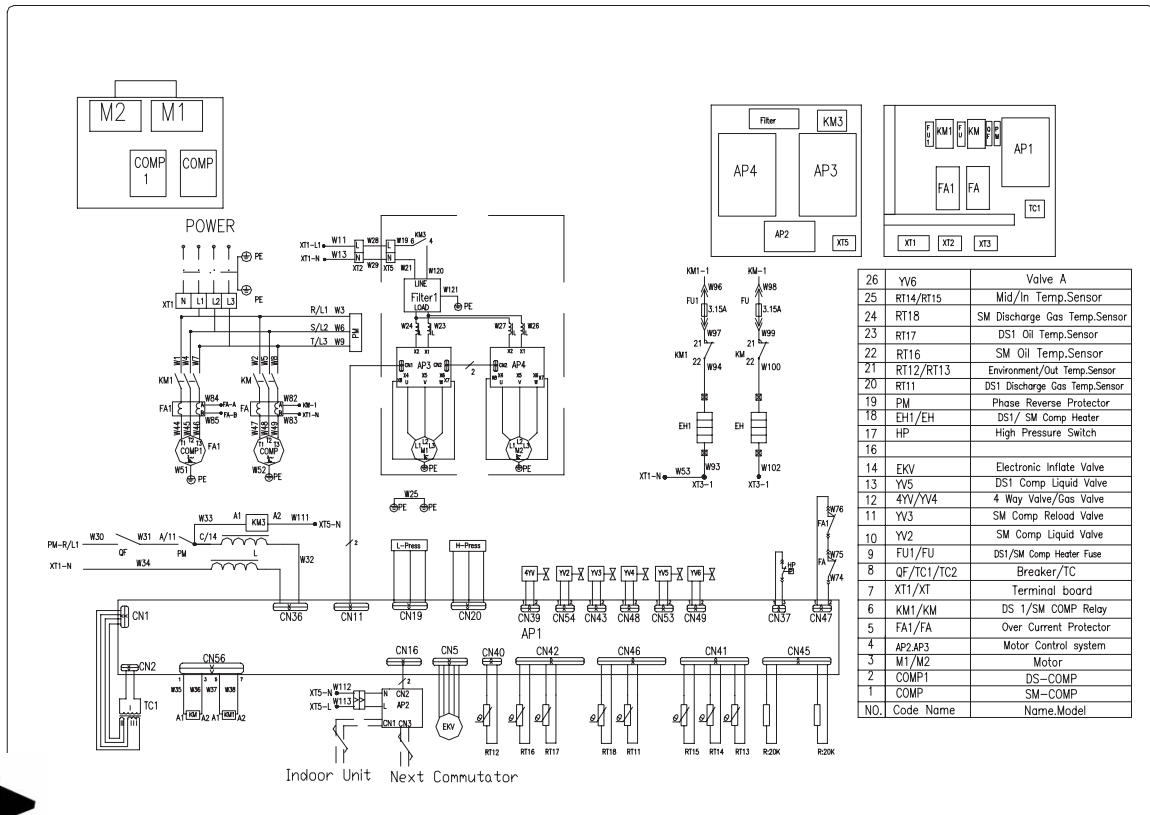

### Модели GMV-Rm400W/Na-M, GMV-Rm450W/Na-M, GMV-Rm504W/Na-M

Большая библиотека технической документации

<https://splitsystema48.ru/instrukcii-po-ekspluatcii-kondicionerov.html>

каталоги, инструкции, сервисные мануалы, схемы.



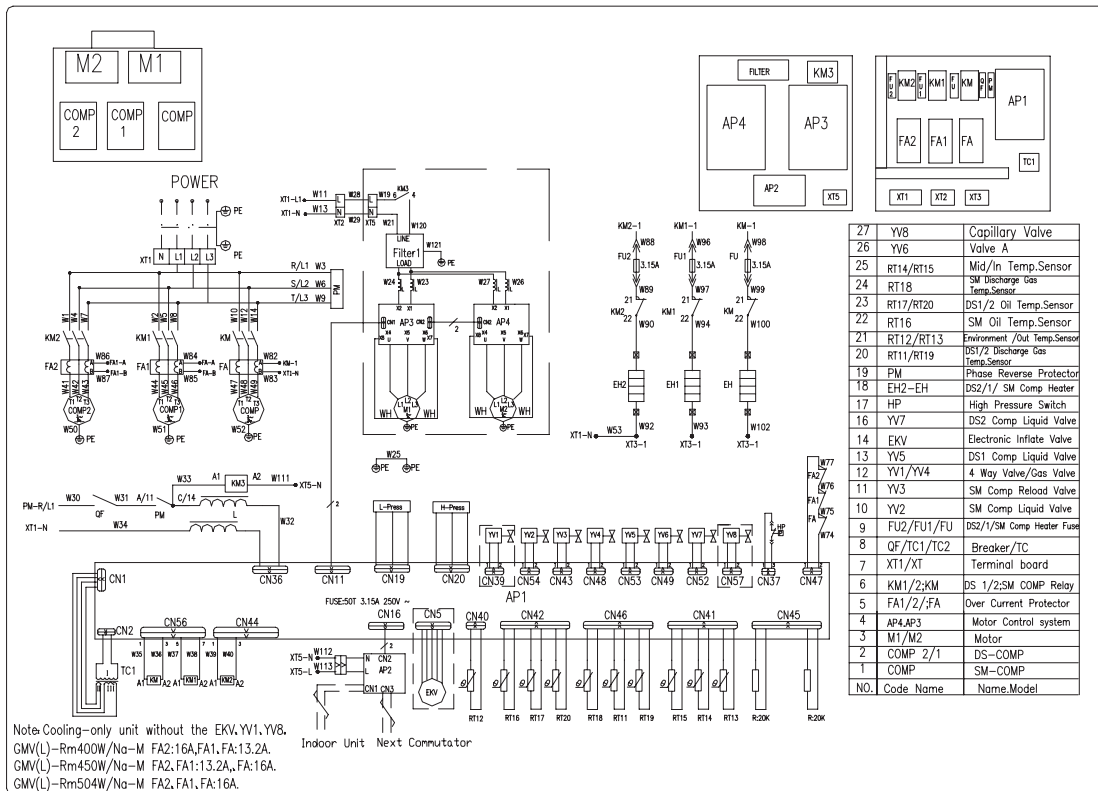

18.2 Электрические схемы внутренних блоков моделей GMV-R22P/Na-K, GMV-R25P/Na-K, GMV-R28P/Na-K, GMV-R36P/Na-K, GMVL-R22P/Na-K, GMVL-R25P/Na-K, GMVL-R28P/Na-K, GMVL-R36P/Na-K.

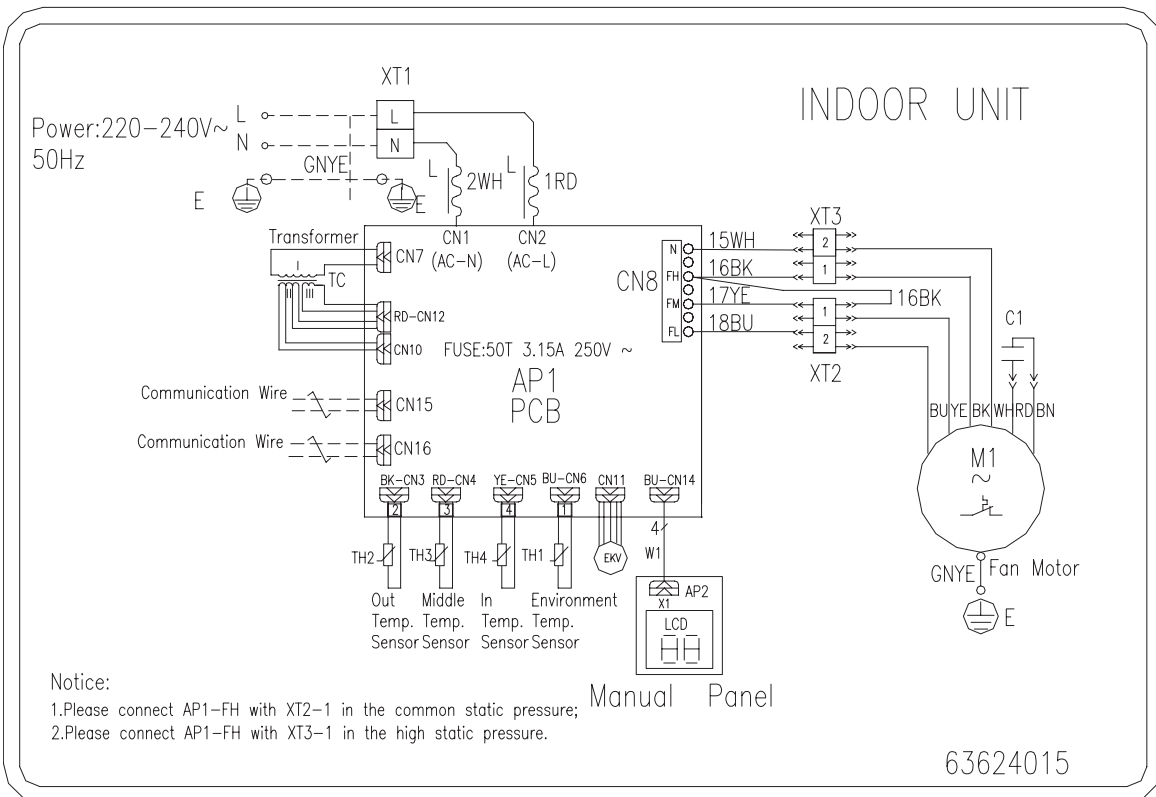

Notice:

1. Please connect AP1-FH with XT2-1 in the common static pressure;
2. Please connect AP1-FH with XT3-1 in the high static pressure.

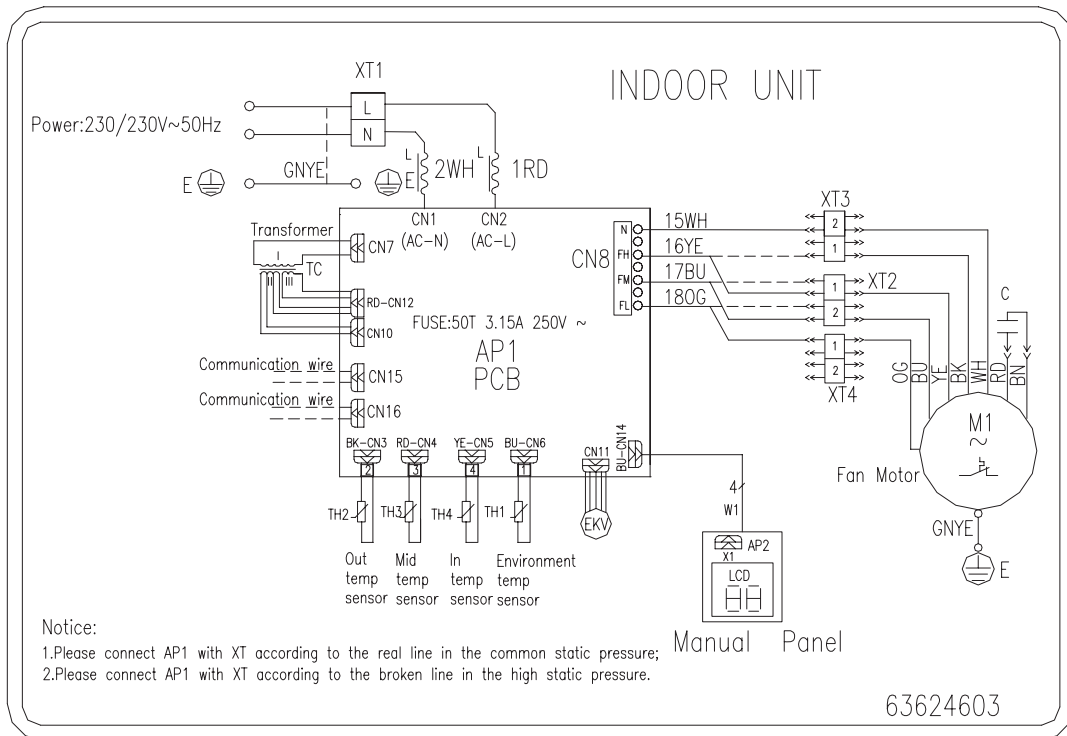

Модели GMV-R56P/Na-K, GMV-R71P/Na-K, GMV-R80P/Na-K, GMVL-R56P/Na-K, GMVL-R71P/Na-K, GMVL-R80P/Na-K.

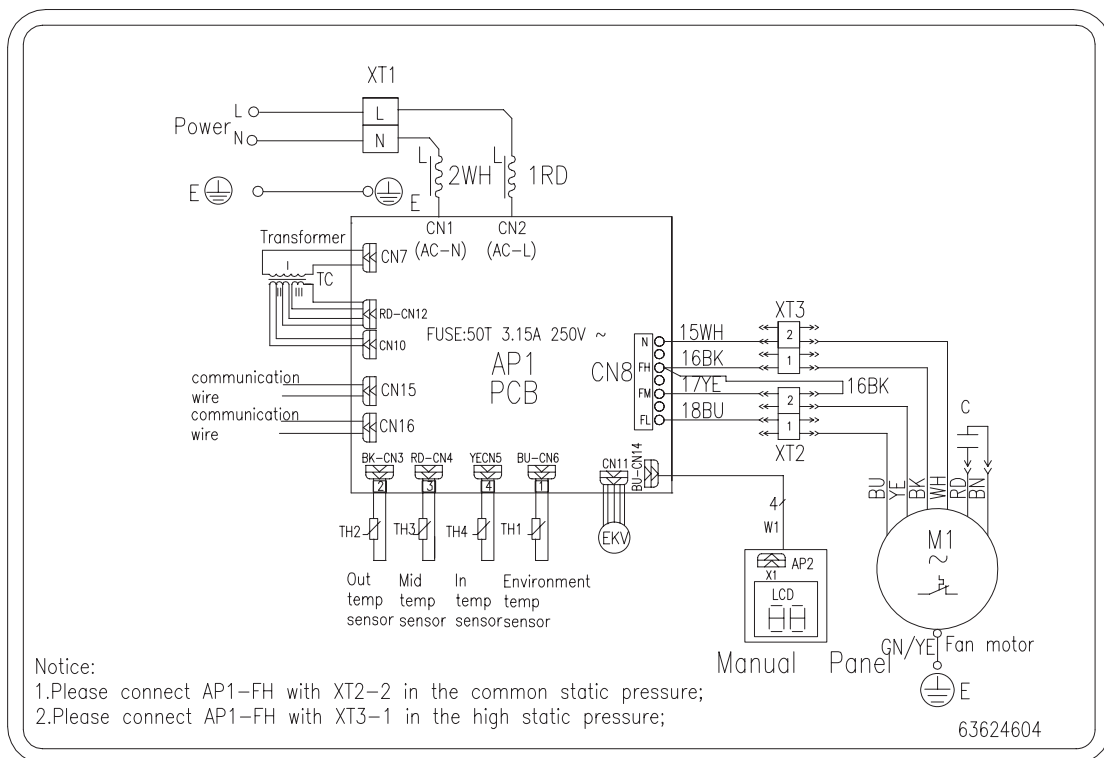

Модели GMV-R90P/Na-K, GMV-R112P/Na-K, GMV-R140P/Na-K, GMVL-R90P/Na-K, GMVL-R112P/Na-K, GMVL-R140P/Na-K.

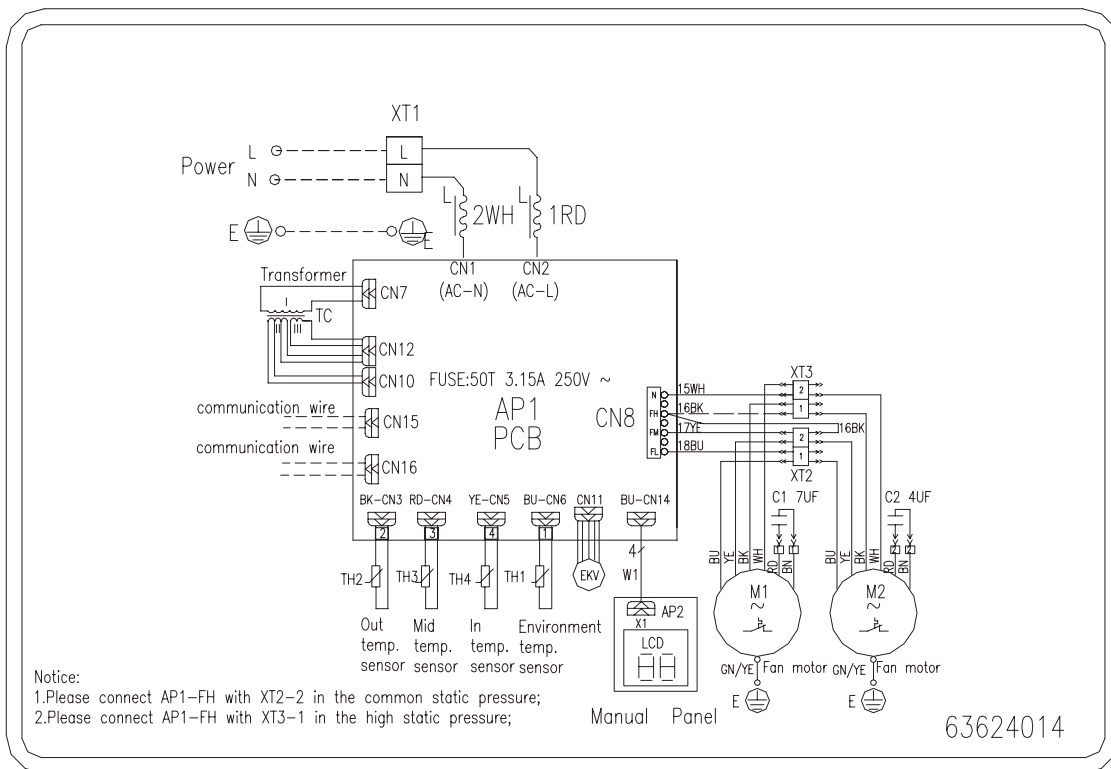

Модели GMV-R125P/Na-K, GMVL-R125P/Na-K.

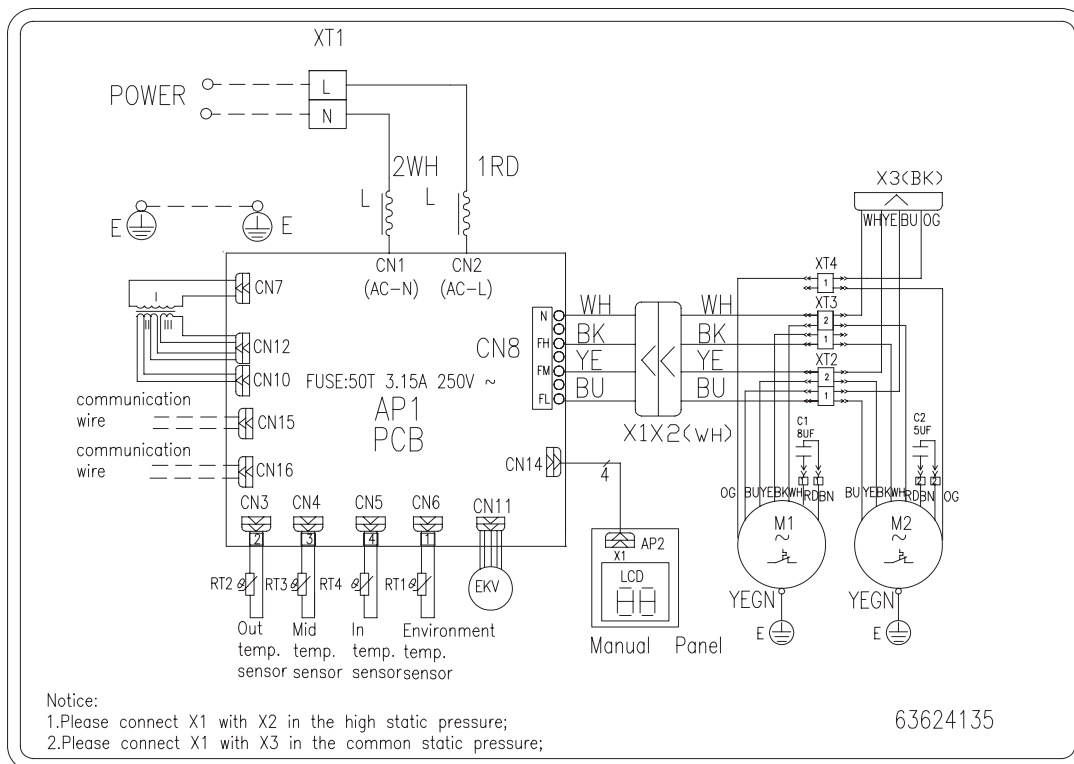

Модели GMV-R22P/NaB-K, GMV-R25P/NaB-K, GMV-R28P/NBa-K, GMV-R32P/NaB-K, GMVL-R36P/NaB-K.



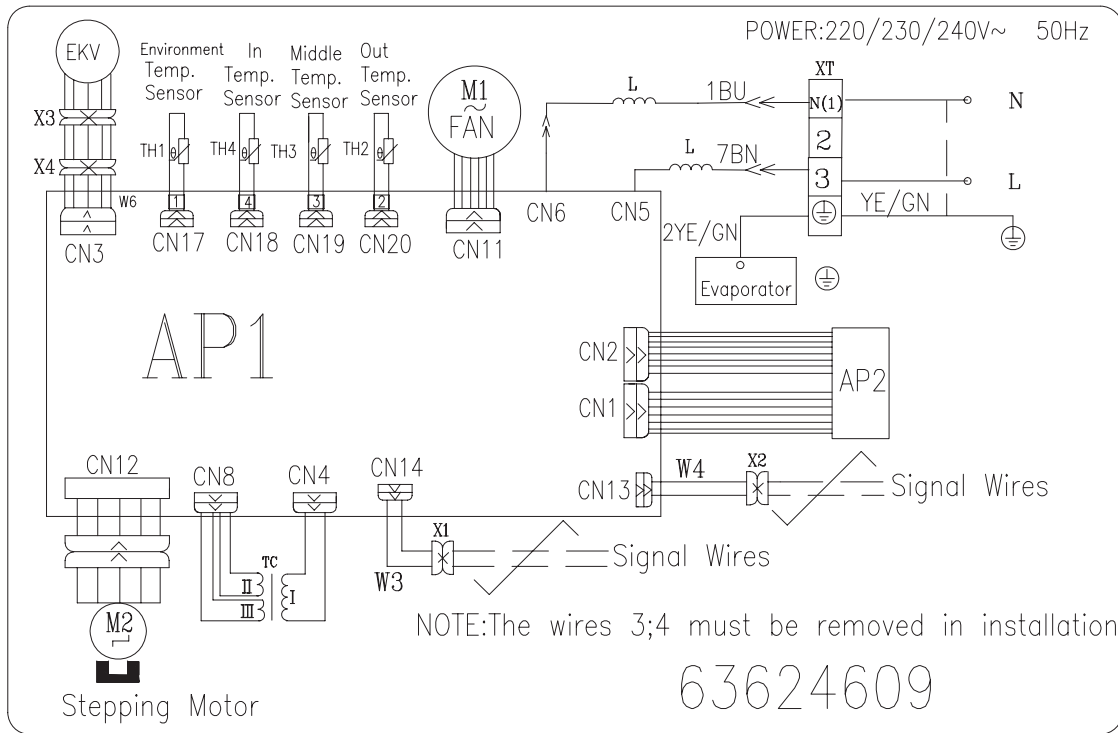

Модели GMV-R50G/NaB-K, GMV-R56G/NaB-K, GMLV-R50G/NaB-K, GMVL-R56G/NaB-K.

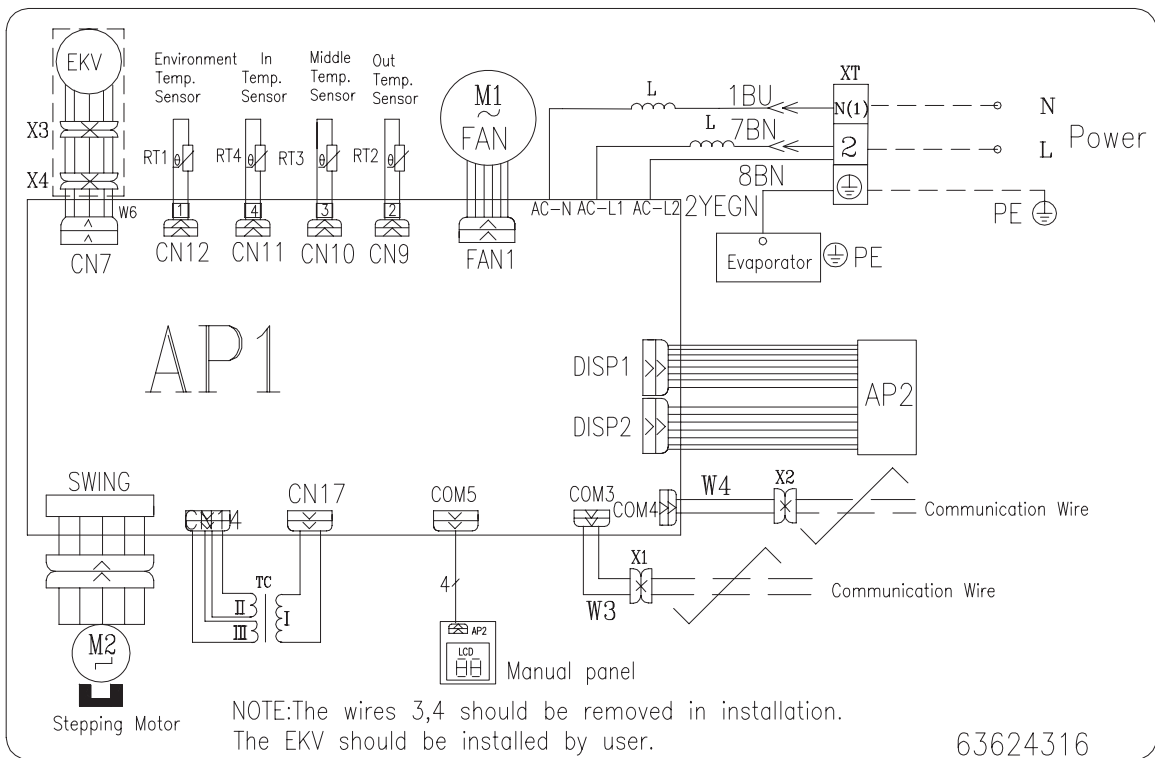

Модели GMV-R22G/NaC-K, GMV-R28G/NaC-K, GMV-R36G/NaC-K, GMV-R45G/NaC-K, GMVL-R22G/NaC-K, GMVL-R28G/NaC-K, GMVL-R36G/NaC-K, GMVL-R45G/NaC-K.

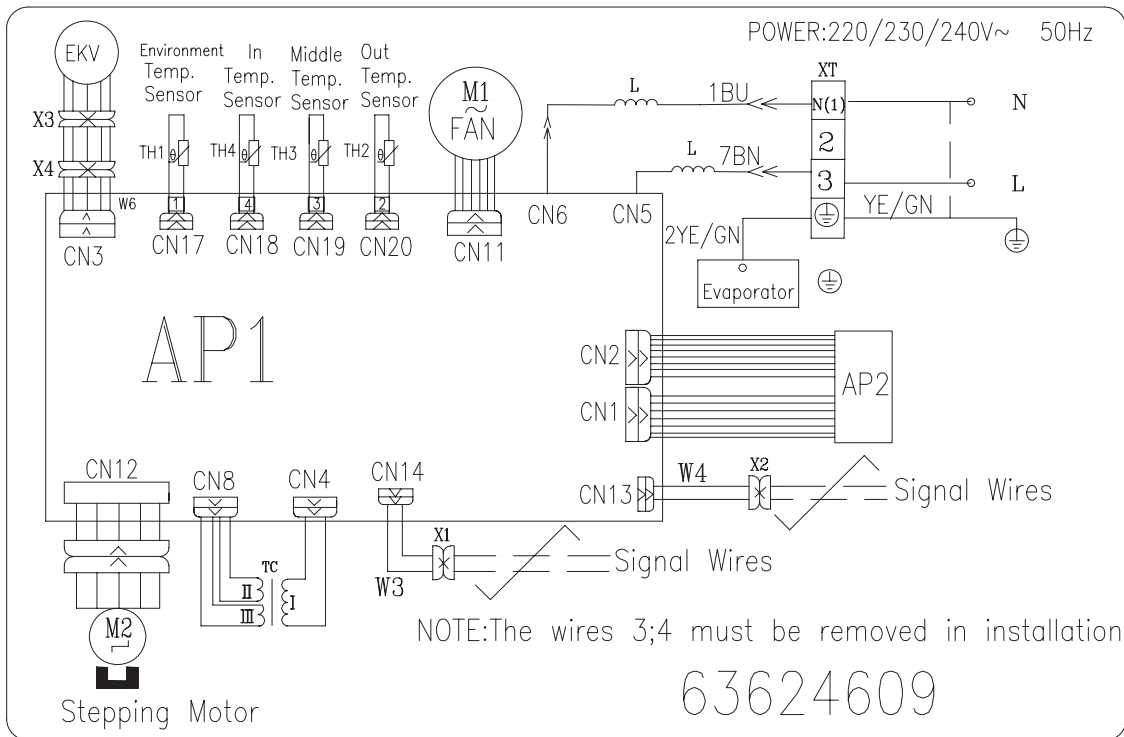

Модели GMV-R71G/Na-K, GMV-R80G/Na-K, GMVL-R71G/Na-K, GMVL-R80G/Na-K.

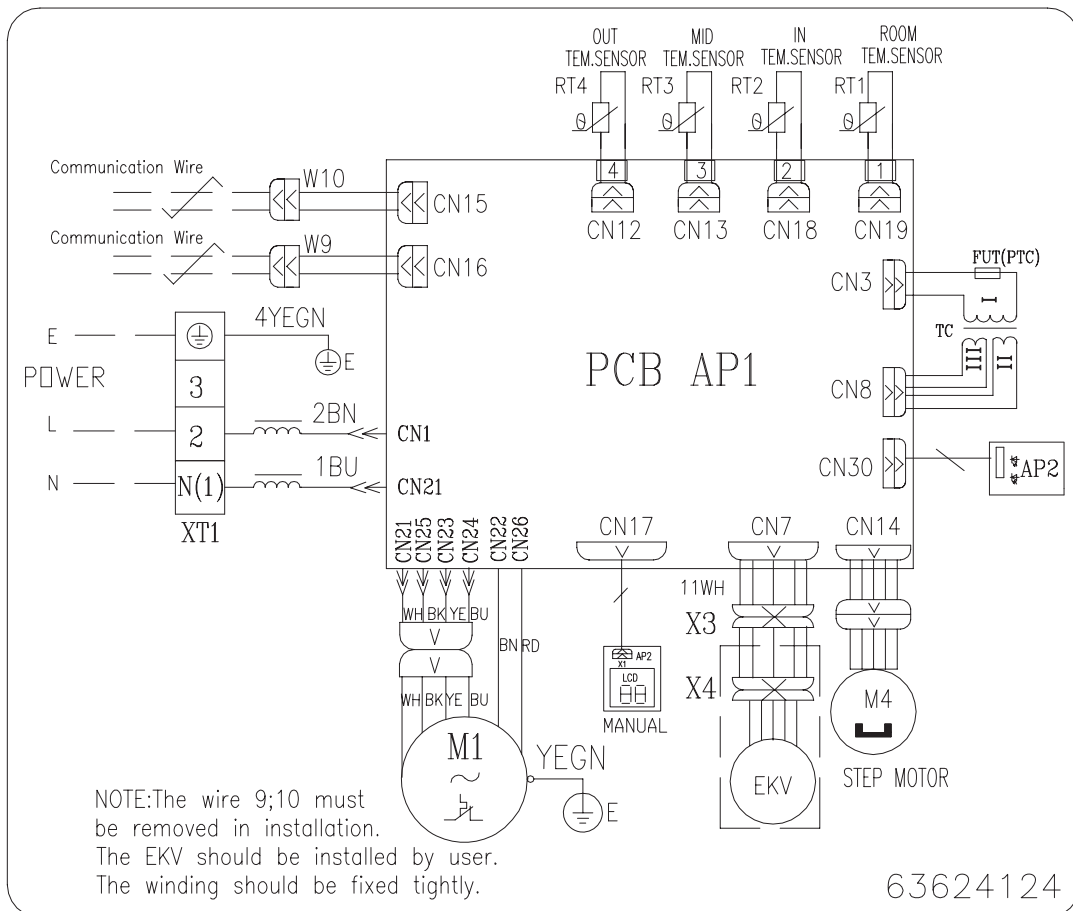

Модели GMV-R28Zd/Na-K, GMV-R36Zd/Na-K, GMV-R50Zd/Na-K, GMV-R71Zd/Na-K, GMV-R90Zd/Na-K, GMV-R112Zd/Na-K, GMV-R125Zd/Na-K, GMVL-R28Zd/Na-K, GMVL-R36Zd/Na-K, GMVL-R50Zd/Na-K, GMVL-R71Zd/Na-K, GMVL-R90Zd/Na-K, GMVL-R112Zd/Na-K, GMVL-R125Zd/Na-K.

